



# Amflex

## FEEDER MACHINE

1 or 2 lanes feeder with 2, 3 or 4 stations

# SPECIFICATION

## Standard Features :

- High quality feeder
- Suction under feeding belts
- Automatic speed synchronization with the ironer
- U Touchscreen panel
- 100 free programmable programs
- Adjustable spreading tension per program
- Adjustable clamp heights
- Automatic start of the clamp
- Inlet rollers above the suction box
- Preparation for M.I.S
- Photocells face down
- Spreading knife in suction box
- Spreading brushers in suction box
- Acoustical Warning alarm
- Servo controlled spreading
- Inlet conveyor speed reduction

## Technical Information :

- Electrical
  - Voltage : 3x400 V+N+PE / 50 Hz
  - Power : 3 kW, Fuses 16A
- Pneumatic
  - Pressure : 6 - 10 Bar
  - Consumption : 3,000 NI/1000 sheets
  - Connection : 3/8" (1/2" tube)
- Miscellaneous
  - Noise level : 75 dBA
  - Speed : 8 up to 50 m/min
- Production Materials Sheets
  - Sheets, table linen, draw sheets, etc.
  - Max. size 1 lane : 3.3 m x working width
  - Min. size 1 lane : 0.9 m x 0.9 m

Specification of design is subject to change without notice.  
For additional options please consult factory and distributor.

## Optional Features :

- Working Width up to 4100 mm.
- Adjustable vacuum suction box
- Stretch conveyor
- Ironer protection
- Inspection light in front of machine
- Stain and tears
- Automatic ironer speed control from feeder
- Lifting device
- Spare parts kit

	Working width A	C	B1	B2	D
1 lane	3000 [118 1/8"]	4170 [164 1/5"]			3 = 1200 (47 1/4") - 4 = 950 (37 1/2")
	3300 [130"]	4170 [164 1/5"]			3 = 1200 (47 1/4") - 4 = 950 (37 1/2")
	3500 [137 4/5"]	4620 [181 7/8"]			3 = 1425 (56") - 4 = 950 (37 1/2")
	3700 [145 2/3"]	4620 [181 7/8"]			3 = 1425 (56") - 4 = 950 (37 1/2")
2 lane	3000 [118 1/8"]	4682 [184 1/4"]	1500 [59"]	1500 [59"]	3 = 1200 (47 1/4") - 4 = 950 (37 1/2")
	3300 [130"]	4682 [184 1/4"]	1650 [65"]	1650 [65"]	3 = 1200 (47 1/4") - 4 = 950 (37 1/2")
	3500 [137 4/5"]	5070 [199 1/2"]	1725 [68"]	1725 [68"]	3 = 1425 (56") - 4 = 950 (37 1/2")
	3700 [145 2/3"]	5070 [199 1/2"]	1875 [73 4/5"]	1875 [73 4/5"]	3 = 1425 (56") - 4 = 950 (37 1/2")

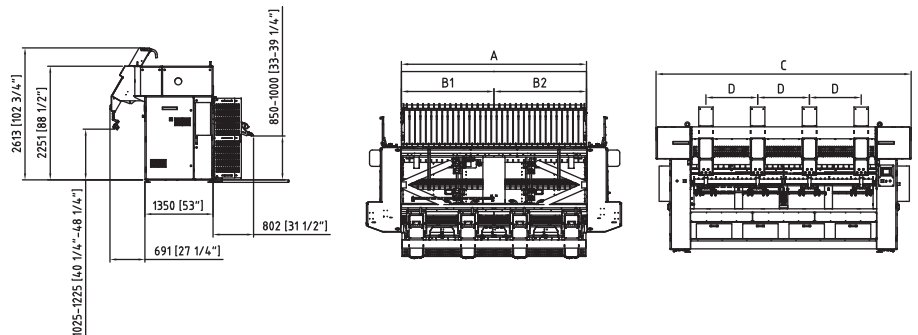

ISO 9001 : 2008

ISO 14001 : 2004

ACCURATE TECHNOLOGIES CO., LTD.

Bangkok, Thailand Phone : +66(0)2740-5511 (Auto) Fax : +66(0)2752-2773

Website : www accuratethai.com Email : sales@ accuratethai.com

Rev. 2015-001