

SPECIFICATION



Standard Features :

- Steam or Gas heating
- Gas heated models for Natural or LP gas
- Variable speed drive with inverter
- Electronic temperature control with digital read out
- Jog forward/reverse
- Front or rear return
- Full exhaust canopy with external blower
- Electrical and mechanical protection devices
- Three phase electrical service
- Chrome plated cylinder
- Lift of interlocked end panels for easy maintenance
- 4 emergency stop buttons around the machine

Optional Features :

- Single phase electrical service

MODEL			IS-18x120	IS-24x120	IS-32x120
Units of Measurement	Matric	US			
Number of Rolls	Roll		1	1	1
Roller Diameter	mm.	inch	457.2 (18")	609.65 (24")	812.8 (32")
Working Width	mm.	inch	3000 (118.1")	3000 (118.1")	3000 (118.1")
Speed Range	M/min	FU/min	2.5-14 (8-45)	3.75-22 (12-72)	4.5-30 (15-98)
Overall Dimensions :					
A - Machine Width	mm.	inch	4060 (159.8")	4060 (159.8")	4060 (159.8")
B - Machine Depth	mm.	inch	1297 (51.5")	1592 (62.7")	1804 (71")
C - Machine Height at full	mm.	inch	2418 (95.2")	2443 (96.2")	2621 (103.2")
D - Canopy Height	mm.	inch	500 (19.7")	500 (19.7")	500 (19.7")
Drive System :					
Drive Motor	kW	HP	0.75 (1)	1.10 (1.5)	2.2 (3)
Delivery Motor	kW	HP	0.25 (0.33)	0.25 (0.33)	0.25 (0.33)
Blower Motor	kW	HP	1.5 (2)	1.5 (2)	1.5 (2)
Power System :					
Power Source	V / Hz / Ph		220/380/415 V / 50 Hz / 3 Ph 208-220/440/460 V / 60 Hz / 3Ph		
Compressed Air System :					
Air Flow	Cmm	Cfm	50 (1764.9)	50 (1764.9)	50 (1764.9)
Exhaust Duct	mm.	inch	254 (10)	254 (10)	254 (10)
Gas Model :					
Gas Inlet Connection	NPT		1"	1"	1"
Gas Consumption	kcal/hr	btu/hr	71713 (284580)	156237 (620000)	207897 (825000)
Net Weight	kg.	lbs.	1730 (3814)	2532 (5582)	2852 (6288)
Domestic Shipping Weight (approx.)	kg.	lbs.	1865 (4112)	2667 (5880)	2987 (6585)
Steam Model :					
Steam Inlet Connection	NPT		3/4"	1-1/4"	1-1/4"
Steam Outlet Connection			1/2"	1/2"	1/2"
Steam Pressure	bar	psi	6.2-8.6 (90-125)	6.2-8.6 (90-125)	6.2-8.6 (90-125)
Steam Consumption	kg/hr	lb/hr	68.86 (151.8)	93.9 (207)	125.2 (276)
Net Weight	kg.	lbs.	1783 (3931)	2585 (5699)	2905 (6404)
Domestic Shipping Weight (approx.)	kg.	lbs.	1917 (4226)	2720 (5997)	3040 (6702)
Electric Heated Model :					
Electrical Heating Power	kW		36	48	N/A
Net Weight	kg.	lbs.	1843 (4063)	2645 (5831)	N/A
Domestic Shipping Weight (approx.)	kg.	lbs.	1973 (4350)	2780 (6129)	N/A

Specification of design is subject to change without notice. For additional options please consult factory and distributor.

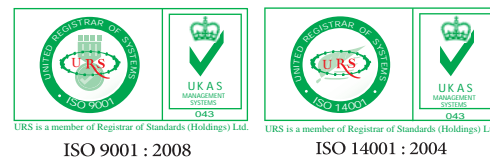
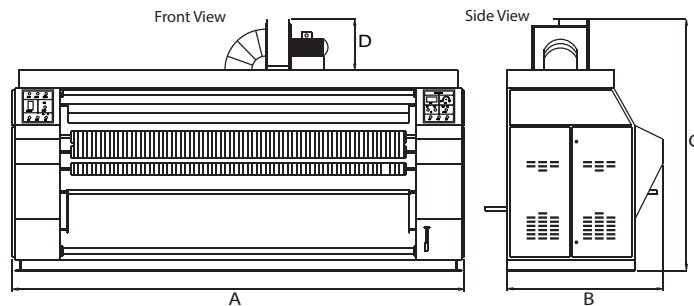

Flatwork Ironer

IS Series

MODEL : IS-18x120, IS-24x120, IS-32x120



IS Series - SINGLE ROLL HIGH PERFORMANCE IRONERS

The Image IS Series - Single Roll High Performance Ironers for Medium to Large On Premise Laundries Demanding High Quality Linen Service

A Full Line of Single Roll Ironers - Compact and Efficient - Easy to Use - Built to Last - Protecting your Investment

The IS series ironers are ideal for medium to large size laundries including resort hospitality, health care and commercial laundries. This line of ironers produce high quality linen finishes easily and efficiently. It has high evaporation power and saves energy. The frame is built with high quality carbon steel primed and painted for long life. The cylinder is chrome plated and supported by heavy-duty lubricated bearings. A large efficient fan pulls evaporated moisture away from the cylinder. The nomex ironing belts used prevent absorption of moisture while ironing, which extends the life of all feed compartments. The compact design occupies very little space and the finished linen can be discharged to be a folder via the front or back of the ironers. These ironers are the most affordable ironers in terms of capital investment, operating expenses, maintenance, and floor space requirement. Discover the difference in elegance and simplicity of features with this ironer line.

Easy to Use Controls and a High Efficiency Inverter Drive for Flexibility

The IS series is equipped with a simple-to-use control system that provides precise temperature regulation. The temperatures are shown on a digital readout. The electronic temperature control provides for adjustment of the ironing temperature at any time during operation. A standard high efficiency variable speed inverter controls the speed in an extended speed range to suit the wide variety of fabrics and moisture retentions. The speed can be adjusted at any time during operation. The variable speed drive provides the inverter that reduces the stress on drive components including sprockets, bearings, shafts and chains. A forward/reverse switch provides flexibility, allowing the linen to be discharged to a folder via the front or rear of the ironers.



Highest Level of Safety

Thoughtful engineering ensures conformity to world safety standards. The control is simple, yet versatile, and has all the safety features that are required to protect the machine and the operator. Features such as electrical circuit protection, emergency stops, safety labels and hand guard with double safety across the full width of the ironer provides peace of mind, as well as long machine life with less maintenance. Environmentally safe temperature resistant textile padding and belts are used. A full size canopy with a powerful exhaust fan (outside for easy cleaning) is provided to optimize vapor evaporation and combustion by-products (gas heated models). A fully enclosed back keeps the heat inside the ironer thus reducing the radiant temperature while saving energy.



The Benefit of Ironing and Image Total Solutions

Discover the affordable alternative and enjoy quality, reliability and trouble free operation. Several factors can significantly affect laundry equipment performance and operational throughput, as well as the quality of the linen being cleaned and finished in the laundry process.

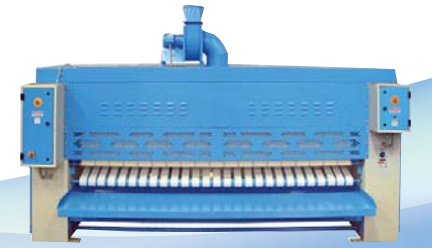

Using high-speed Image washer-extractors in combination with Image ironers improves the productivity and increases the quality. The most efficient way of removing moisture from linen is by high extraction and ironing. Our ironers are built to handle the linen direct from our washers.



This is the most economical way of producing high quality work as Image total solutions enables savings in energy, time and labour. In addition, the capital expenses for Image quality ironers are significantly lower making it the best for less. The Image ironers are designed for simplicity without complicated controls and devices, therefore preventing causes which can stop production.



Discover the features and the value of Image ironers and other products for any laundry application, from family drycleaning-laundry operations to large industrial high productivity operations. Image can supply total solutions of laundry equipment which will benefit you most.

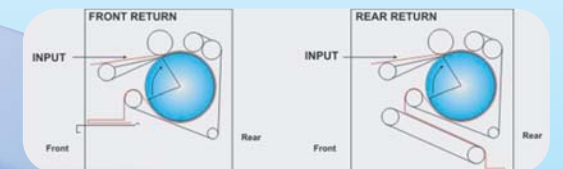

Ironed linen conveys a message of first class quality and cleanliness. Linen that is tumble dried only often gives the impression that it has already been used by a previous guest. Our ironers provide the finest quality finish to laundry, crisply ironing linen such as napkins, bedsheets and pillowcases.